

CURVE E DATI DI PRESTAZIONE / CURVES AND PERFORMANCE DATA

n= 2900 1/min

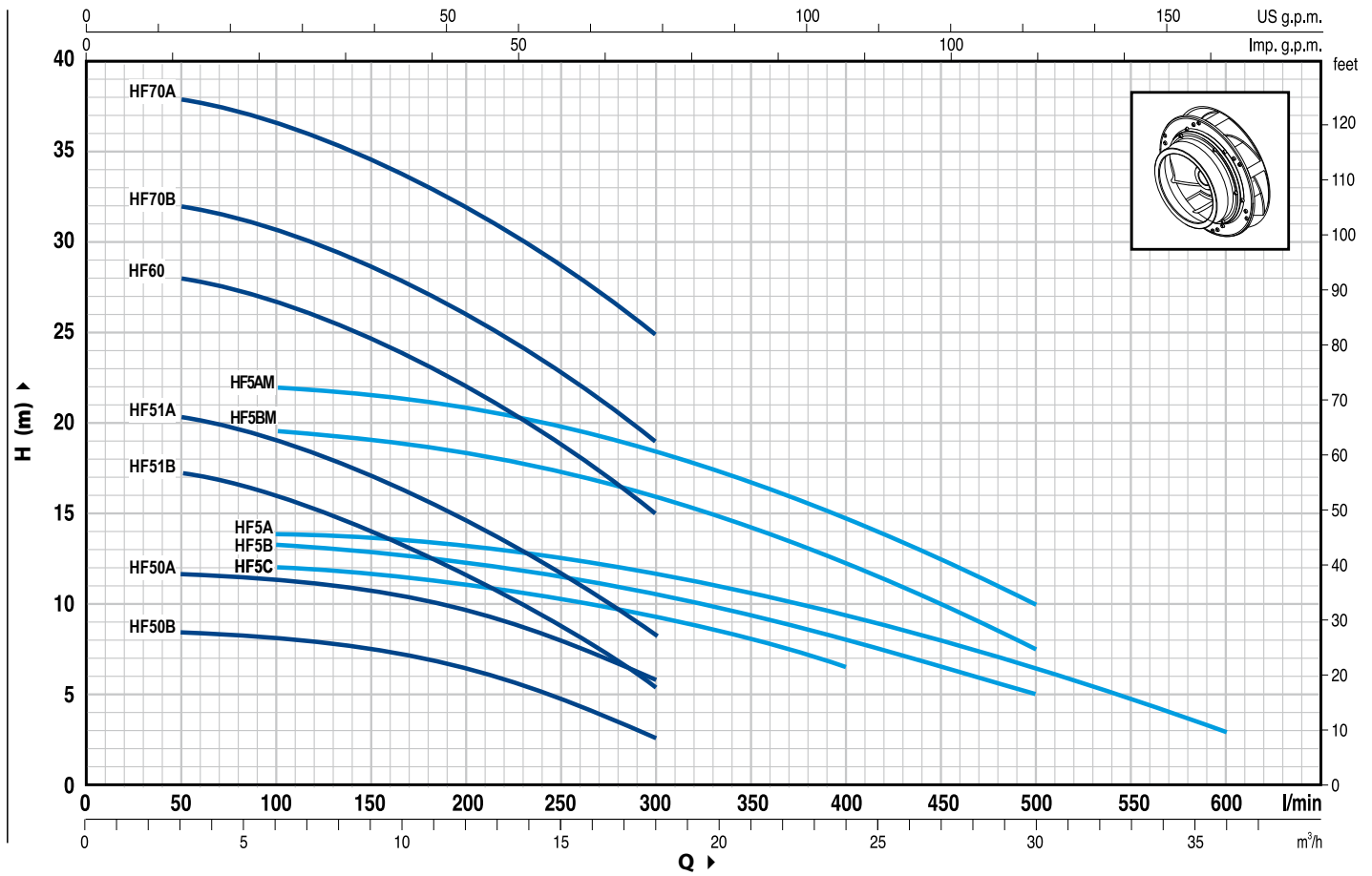

MODELLO TYPE		POTENZA POWER		Q m³/h l/min	H (m)													
1 ~	3 ~	kW	HP		0	3	6	9	12	15	18	21	24	30	36			
HFm 50B	HF 50B	0.37	0.50	9	8.5	8.2	7.5	6.3	4.9	2.8								
HFm 50A	HF 50A	0.55	0.75	12	11.5	11.2	10.6	9.6	8	6								
HFm 51B	HF 51B	0.60	0.85	18.2	17.2	16	14	11.5	9	5.4								
HFm 51A	HF 51A	0.75	1	21.2	20.2	19	17	14.5	11.6	8.4								
HFm 60	HF 60	1.1	1.5	29	28	26.5	24.5	22	18.5	15								
HFm 70B	HF 70B	1.5	2	33	32	30.5	28.5	26	22.5	19								
—	HF 70A	2.2	3	39	38	36.5	34.5	32	28.5	25								
HFm 5C	HF 5C	0.60	0.85	12.5	—	12	11.7	11	10.2	9.2	8	6.5						
HFm 5B	HF 5B	0.75	1	13.7	—	13.2	13	12.5	11.6	10.5	9.2	8	5					
HFm 5A	HF 5A	1.1	1.5	14.5	—	13.8	13.5	13.2	12.6	11.8	10.5	9.2	6.5	3				
HFm 5BM	HF 5BM	1.1	1.5	20.2	—	19.2	19	18	17	16	14	12	7.5					
HFm 5AM	HF 5AM	1.5	2	22.5	—	22	21.5	21	20	18.5	16.6	14.5	10					

Q = Portata H = Prevalenza manometrica totale
 Q = Flow rate H = Total manometric head

Tolleranza delle curve di prestazione secondo EN ISO 9906 App. A.
 Tolerance of the performance curves according to EN ISO 9906 App. A.App. A.

DIMENSIONI E PESI / DIMENSIONS AND WEIGHTS

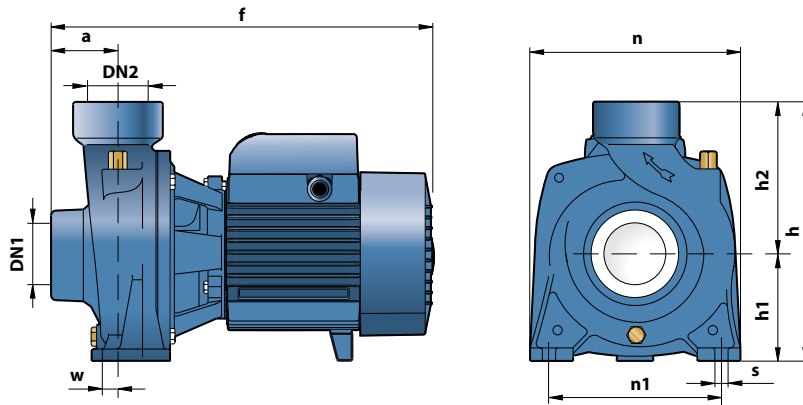

TIPO TYPE		BOCCHIE PORTS		DIMENSIONI mm DIMENSIONS mm									kg	
1~	3~	DN1	DN2	a	f	h	h1	h2	n	n1	w	s	1~	3~
HFm 50B	HF 50B	1 1/2"	1 1/2"	45	276	200	82	118	165	135	1	10	8.1	7.6
HFm 50A	HF 50A				283/276								8.7	8.3
HFm 51B	HF 51B				300								12.9	11.9
HFm 51A	HF 51A			300	13.0	12.0								
HFm 60	HF 60			48.5	373	269	114	155	216	171	12	12	19.0	18.6
HFm 70B	HF 70B			—	—	—	—	—	—	—	—	—	—	—
—	HF 70A	—	—	—	—	—	—	—	—	—	—	—	—	21.9
HFm 5C	HF 5C	2"	2"	60	332	238	97	141	196	160	14	11	14.5	13.3
HFm 5B	HF 5B												14.5	13.3
HFm 5A	HF 5A												15.3	14.9
HFm 5BM	HF 5BM			51	386	260	110	150	206	1	19.5	18.9		
HFm 5AM	HF 5AM			22.0	20.9									

- Corpo pompa: ghisa
- Girante: ottone

- Pump body: cast iron
- Impeller: brass